

Conical mixer

patented

Ideal mixing quality for dry, moist and viscous materials at variable filling levels

For materials with explosive dust, tip speed less than 1 m/s!

The spiral mixing blade initiates a three-dimensional flow of the mixing goods; creating a helical upward movement on the periphery and downward flow in the centre. This conical mixer guarantees very good mixing results and complete discharge. It can be used for dry powder, wet suspensions as well as liquids, paste and dough.

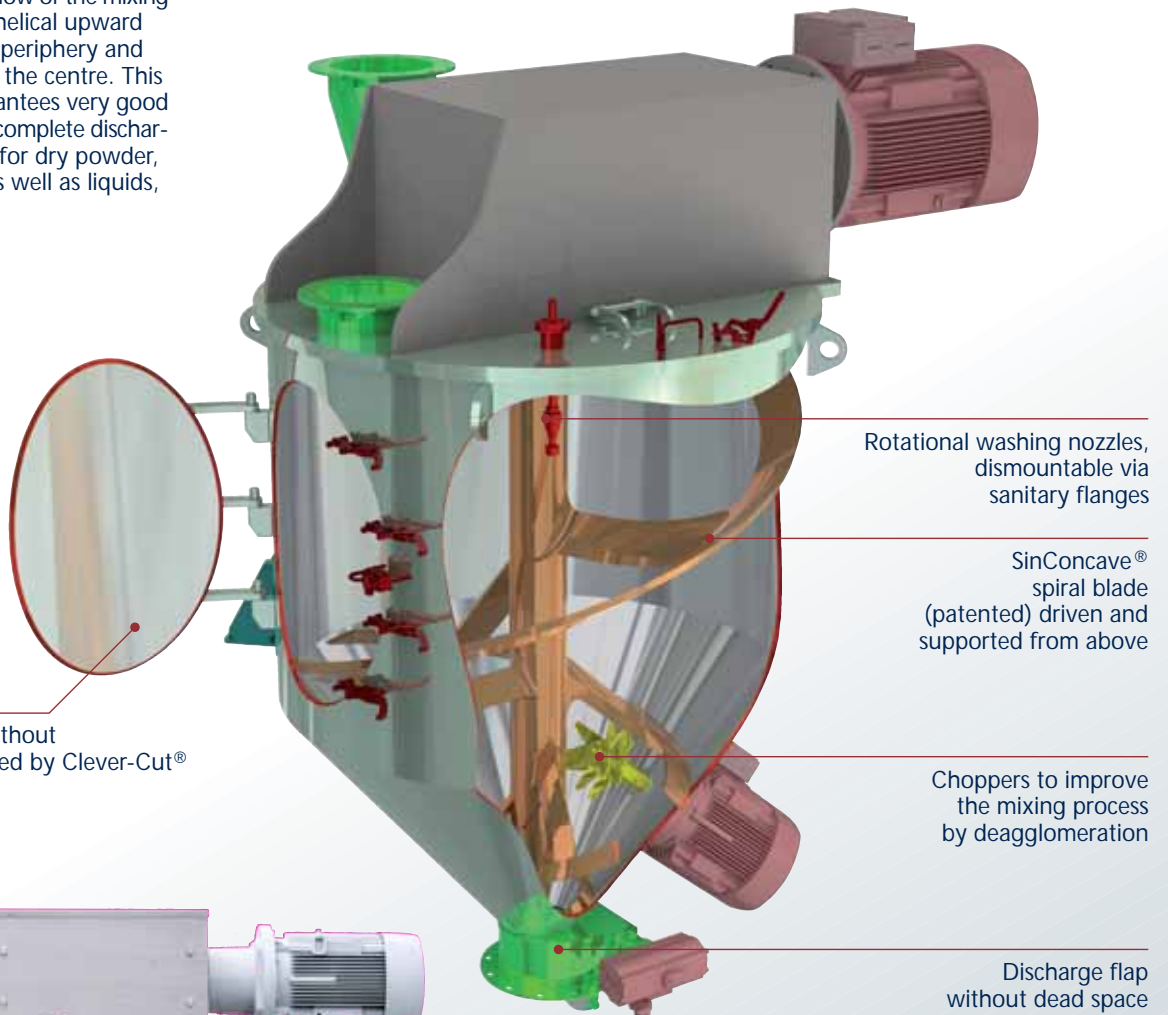

Inspection door without dead space designed by Clever-Cut®

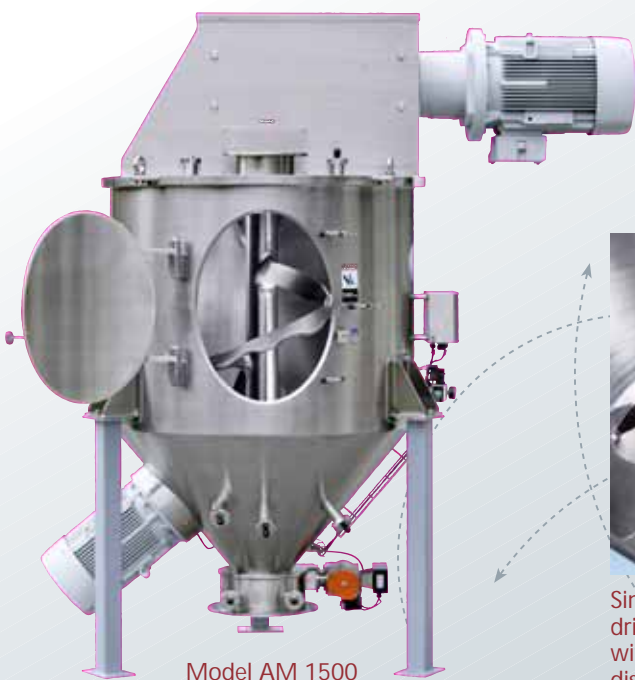

SinConvex® spiral blade (patented) driven and supported from above with the advantage of complete discharge



Inspection door designed by Clever-Cut®

Cone mixer, Model AM

Model	ca. dimensions in mm, ca. weight in kg					
	A	B	C	D	E	Weight
100	360	700	157	600	1100	730
200	430	900	157	750	1350	890
300	420	1035	157	815	1450	940
400	410	1170	157	880	1550	1040
500	420	1230	157	940	1575	1350
600	430	1290	157	1000	1600	1560
800	410	1480	157	1000	1600	1870
1000	530	1560	157	1180	1900	2080
1500	750	1630	157	1490	2200	3330
2000	780	1940	157	1490	2250	3600
2500	790	2380	165	1490	2750	3850
3000	800	2290	157	1710	2650	4370
4000	810	2420	157	1870	2400	5540
5000	810	2360	157	2010	2600	7590
6000	810	2650	157	2150	2650	8130
7000	880	2845	157	2270	2900	8840
8000	950	3040	157	2390	3200	9880
9000	950	3075	157	2595	3350	10400
10000	950	3110	157	2800	3500	11440
12000	1000	3480	157	2800	3500	13520
15000	1100	3800	157	2800	3800	15600

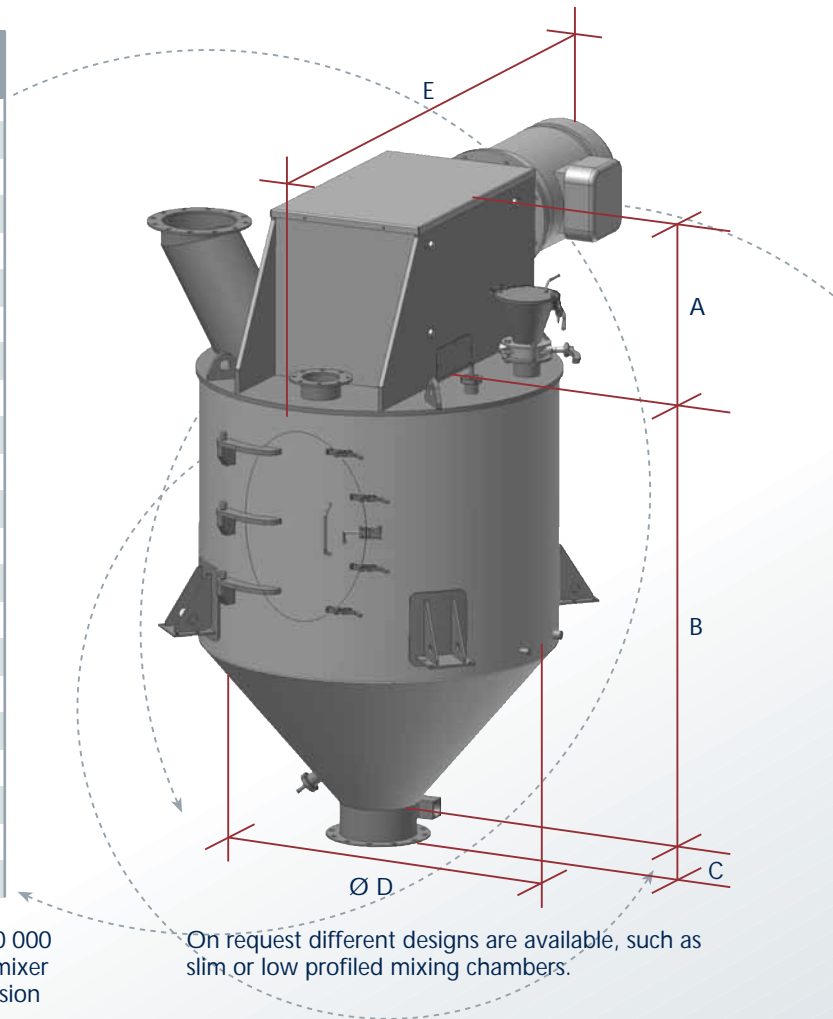

Interim sizes are offered in 100 litre steps. Bigger mixers up to 50 000 litres, available on demand. Depending on the user needs the mixer weight may be lower or higher. Please ask for individual dimension sheets.

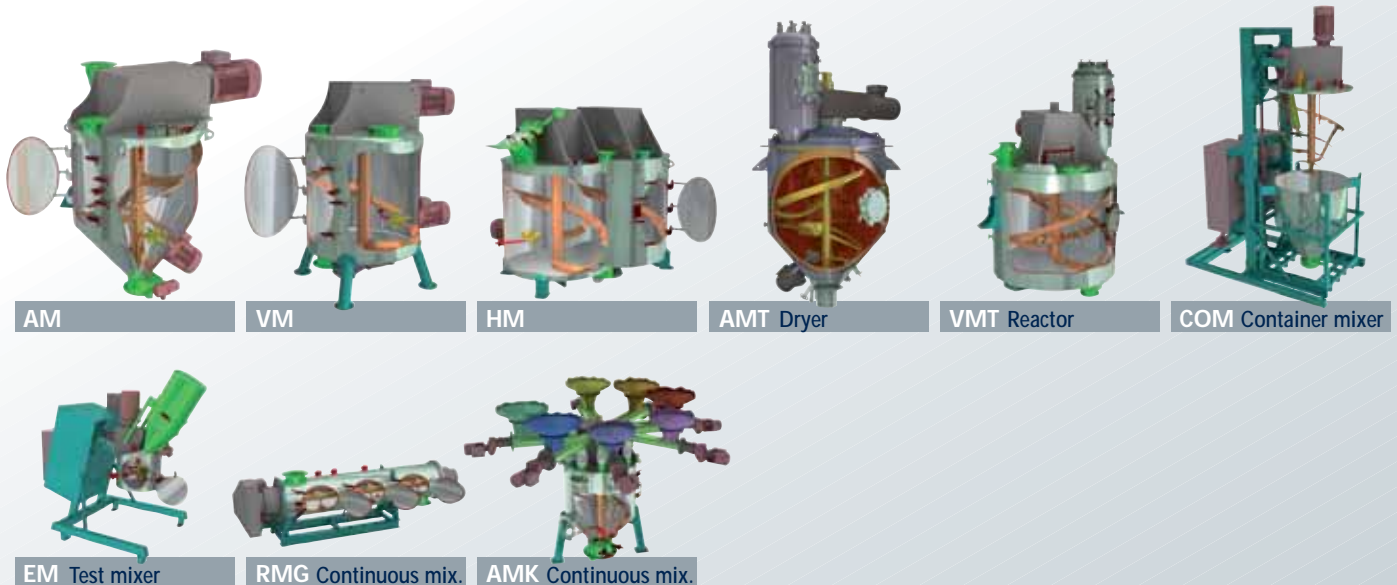

amixon® test laboratories are available in Paderborn, Germany, in Memphis, USA and in Osaka, Japan. On request amixon can prepare detailed qualification documents.

We reserve the right to make changes due to progress in process engineering and manufacturing technology.
© by amixon GmbH, Paderborn. Reprinting or transfer to electronic media only permitted after written approval.

amixon® GmbH

Halberstädter Straße 55
D-33106 Paderborn (Germany)

Phone +49 (0) 52 51 / 68 88 88 - 0
Fax +49 (0) 52 51 / 68 88 88 - 999
e-mail info@amixon.de

www.amixon.com